

Jet pump AJ-S



Product advantages

- New design with stainless steel pump housing
- Jet pump with PPO impeller and nozzle assembly, welded stainless steel rotor shaft
- Integrated thermal protection and watertight terminal box contribute to better pump protection

Technical data

AJS | 55

| 75

Max. head (m)	38	44
Max. Flow (m ³ /h)	4	4.5
Max. suction head (m)	9	9
Power P2 (kW)	0.55	0.75
Supply voltage	1x230V, 50Hz	1x230V, 50Hz
Protection class	IP44	IP44
Ambient temperature (°C)	40	40
Fluid temperature (°C)	40	40
Max. system pressure (bar)	4.8	4.8
Insulation class	Class B	Class B
Pump housing material	stainless steel	stainless steel
Impeller material	PPO	PPO
Cable	1.5m Length incl. protective power plug	1.5m Length incl. protective power plug

Article No
| P OP340 7151

Article No
| P OP340 7150

Hydraulic characteristics

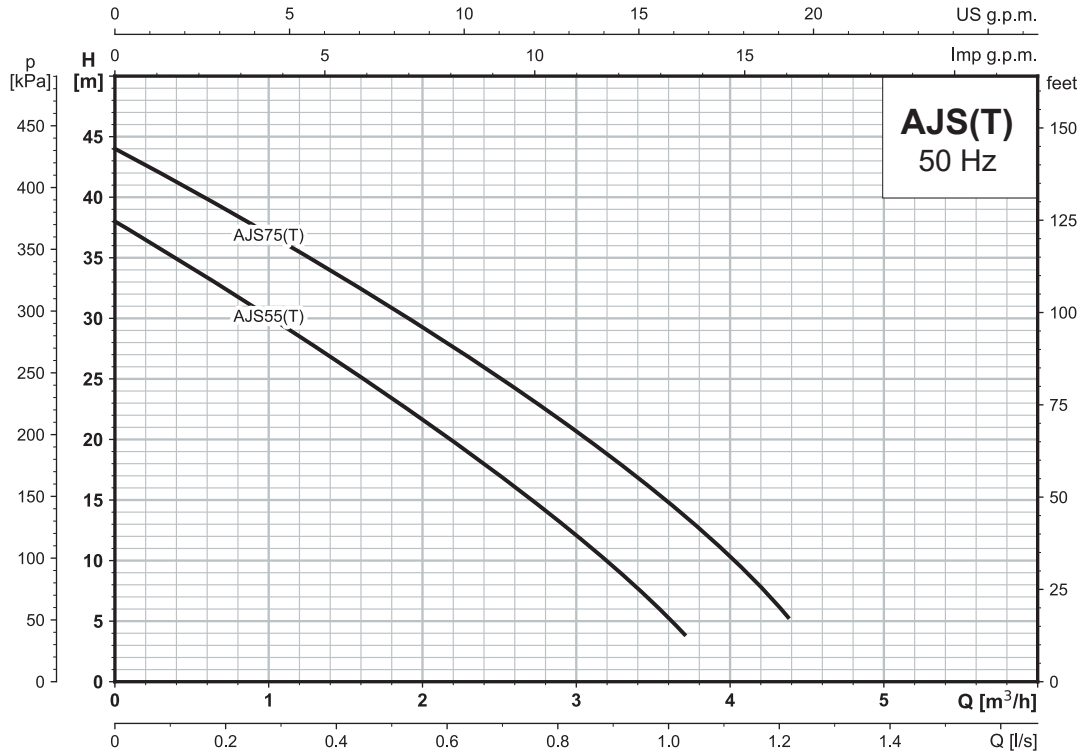

Dimensions and Weight

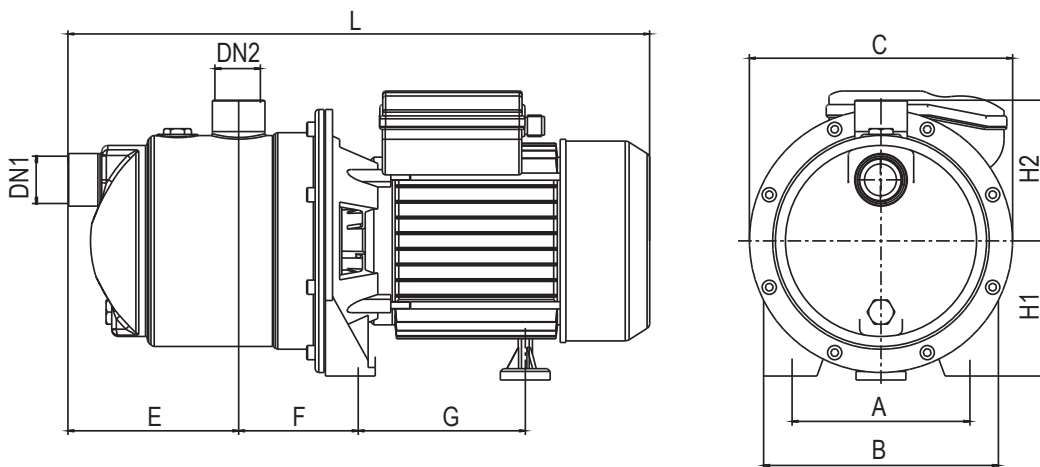

Model	Connections		Dimensions (mm)								Weight (kg)		
	DN1	DN2	A	B	C	E	F	G	L	H1	H2	N.W.	G.W.
Single-phase													
AJS55	1"	1"	125	165	185	76.5	83.5	114.5	371	95	99	8.8	9.3
AJS75	1"	1"	125	165	185	76.5	83.5	114.5	371	95	99	10.2	10.7