

Centrifugal pump ACm



Product advantages

- Innovative design, optimised engine - and hydraulic performance

Technical data

ACm | 75

Max. head (m)	32
Max. Flow (m ³ /h)	7.2
Max. suction head (m)	7
Power P2 (kW)	0.75
Supply voltage	1x230V, 50Hz
Protection class	IP44
Ambient temperature (°C)	40
Fluid temperature (°C)	40
Max. system pressure (bar)	6
Insulation class	Class B
Pump housing material	cast iron
Impeller material	stainless steel
Cable	1.5m Length incl. protective power plug

Article No
| P OP340 7504

Hydraulic characteristics

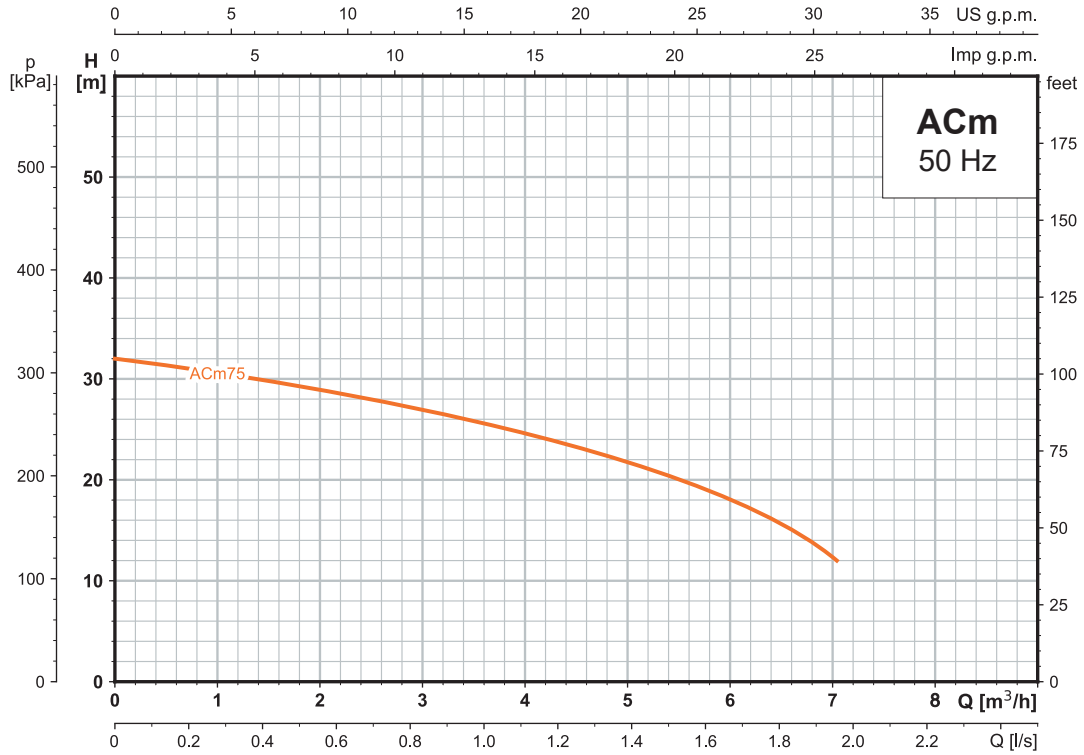

Dimensions and Weight

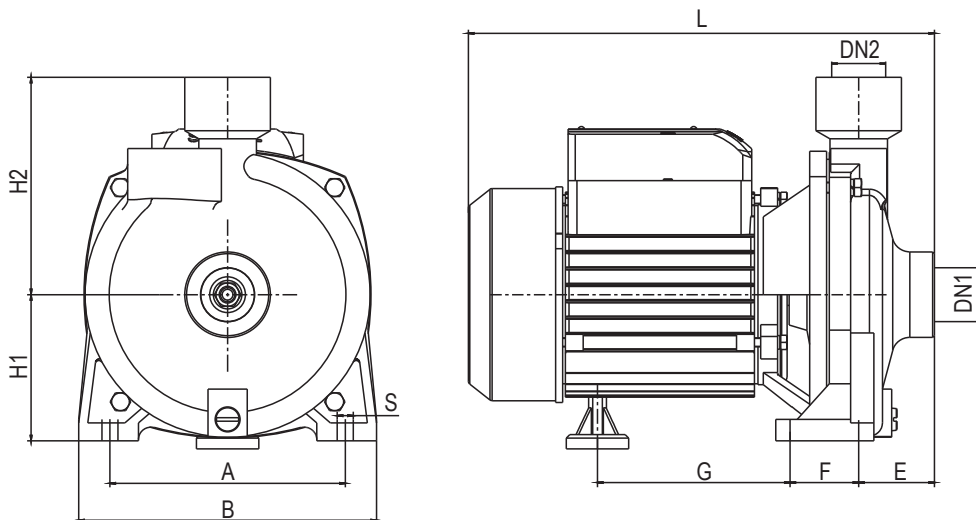

Model	Connections		Dimensions (mm)									Weight (kg)	
	DN1	DN2	A	B	E	F	G	L	S	H1	H2	N.W.	G.W.
ACm75	1"	1"	140	182	47	38	112	294	10	100	144	13.5	13.8